

# PWC KIT – RF DESS Schlüssel ohne Kabelbaum

Produkt: **Sea-Doo\_watercraft**  
 Projekt Nein: **487802284\_rev3**  
 Anleitung P/N: **487802284**  
 Überarbeitung Nr: **3**  
 Änderungsdatum: **Mai 2020**  
 Abgedeckter Artikel: **RF DESS-Schlüssel ohne Kabelbaum,  
 Für Spark-Modelle ohne iBR ist der Kabelbaum (P/N 278003491) für die  
 Installation erforderlich.,  
 Für Spark-Modelle mit iBR, 2017 und früher, ist der Kabelbaum (P/N 278003490)  
 für die Installation erforderlich .,  
 Für Spark-Modelle mit iBR ab 2018 ist der Kabelbaum (P/N 278003823) für die  
 Installation erforderlich.,  
 Für Spark Trixx-Modelle ab 2017 ist der Kabelbaum (P/N 278003490 und  
 278003195) erforderlich Installation.,  
 Für Spark Trixx-Modelle ab 2018 ist der Kabelbaum (P/N 278003823 und  
 278003195) für die Installation erforderlich.**

Die folgenden Symbole können in diesem Dokument verwendet werden:

 **WARNUNG**

Weist auf eine gefährliche Situation hin, die zum Tod oder zu schweren Verletzungen führen kann, wenn sie nicht vermieden wird.

 **VORSICHT:** Weist auf eine Gefahrensituation hin, die, wenn sie nicht vermieden wird, zu leichten oder mittelschweren Verletzungen führen kann.

**HINWEIS** Weist auf eine Anweisung hin, deren Nichtbeachtung zu schweren Schäden an Fahrzeugkomponenten oder anderem Eigentum führen kann.

 **WARNUNG**

- Aus Sicherheitsgründen muss dieses Kit von einem autorisierten BRP-Händler installiert werden.
- Dieses Kit ist nur für bestimmte zutreffende Modelle ausgelegt (autorisierte BRP-Händler bestätigen die Modelle). Es wird nicht für andere Geräte als das (die) empfohlen, für die es verkauft wurde.
- Wenn für die Installation des Kits eine Schablone erforderlich ist, stellen Sie sicher, dass die Schablone maßstabsgetreu ist.
- Sollte bei der Demontage/Montage das Entfernen einer Verriegelung (z. B. Sicherungslaschen, selbstsichernde Verschlüsse etc.) erforderlich sein, immer durch eine neue ersetzen.
- Die Anzugsvorgaben für Drehmomentschlüssel müssen unbedingt eingehalten werden.

**HINWEIS : VERWENDEN SIE DIE ANZUGSDREHMOMENTE IN DER FOLGENDEN TABELLE, WENN NICHT ANDERS ANGEGBEN.**

	GRAD			
	5.8	8.8	10.9	12.9
M4	$1,8 \pm 0,2 \text{ N}\cdot\text{m}$ ( $16 \pm 2$ lbf• Zoll )	$2,8 \pm 0,2 \text{ N}\cdot\text{m}$ ( $25 \pm 2$ lbf• Zoll )	$3,8 \pm 0,2 \text{ N}\cdot\text{m}$ ( $34 \pm 2$ lbf• Zoll )	$4,5 \pm 0,5 \text{ N}\cdot\text{m}$ ( $40 \pm 4$ lbf• Zoll )
M5	$3,3 \pm 0,2 \text{ N}\cdot\text{m}$ ( $29 \pm 2$ lbf• Zoll )	$5 \pm 0,5 \text{ N}\cdot\text{m}$ ( $44 \pm 4$ lbf• Zoll )	$7,8 \pm 0,7 \text{ N}\cdot\text{m}$ ( $69 \pm 6$ lbf• Zoll )	$9 \pm 1 \text{ N}\cdot\text{m}$ ( $80 \pm 9$ lbf• Zoll )
M6	$7,5 \pm 1 \text{ N}\cdot\text{m}$ ( $66 \pm 9$ lbf• Zoll )	$10 \pm 2 \text{ N}\cdot\text{m}$ ( $89 \pm 18$ lbf• Zoll )	$12,8 \pm 2,2 \text{ N}\cdot\text{m}$ ( $113 \pm 19$ lbf• Zoll )	$16 \pm 2 \text{ N}\cdot\text{m}$ ( $142 \pm 18$ lbf• Zoll )
M8	$15,3 \pm 1,7 \text{ N}\cdot\text{m}$ ( $135 \pm 15$ lbf• Zoll )	$24,5 \pm 3,5 \text{ N}\cdot\text{m}$ ( $18 \pm 3$ lbf•ft )	$31,5 \pm 3,5 \text{ N}\cdot\text{m}$ ( $23 \pm 3$ lbf•ft )	$40 \pm 5 \text{ N}\cdot\text{m}$ ( $30 \pm 4$ lbf•ft )

M10	29 ± 3 N•m ( 21 ± 2 lbf•ft )	48 ± 6 N•m ( 35 ± 4 lbf•ft )	61 ± 9 N•m ( 45 ± 7 lbf•ft )	73 ± 7 N•m ( 54 ± 5 lbf•ft )
M12	52 ± 6 N•m ( 38 ± 4 lbf•ft )	85 ± 10 N•m ( 63 ± 7 lbf•ft )	105 ± 15 N•m ( 77 ± 11 lbf•ft )	128 ± 17 N•m ( 94 ± 13 lbf•ft )
M14	85 ± 10 N•m ( 63 ± 7 lbf•ft )	135 ± 15 Nm ( 100 ± 11 lbf•ft )	170 ± 20 N•m ( 125 ± 15 lbf•ft )	200 ± 25 N•m ( 148 ± 18 lbf•ft )
M16	126 ± 14 N•m ( 93 ± 10 lbf•ft )	205 ± 25 N•m ( 151 ± 18 lbf•ft )	255 ± 30 N•m ( 188 ± 22 lbf•ft )	305 ± 35 N•m ( 225 ± 26 lbf•ft )
M18	170 ± 20 N•m ( 125 ± 15 lbf•ft )	273 ± 32 N•m ( 201 ± 24 lbf•ft )	330 ± 25 N•m ( 243 ± 18 lbf•ft )	413 ± 47 N•m ( 305 ± 35 lbf•ft )

HINWEIS : Die Abbildungen in diesem Dokument zeigen typische Konstruktionen der verschiedenen Baugruppen und geben möglicherweise nicht alle Details oder die genaue Form der Teile wieder; sie stellen jedoch Teile mit gleicher oder ähnlicher Funktion dar.

HINWEIS : Die Installationszeit beträgt ca. 0,75 Stunden.

Zu installierende Teile

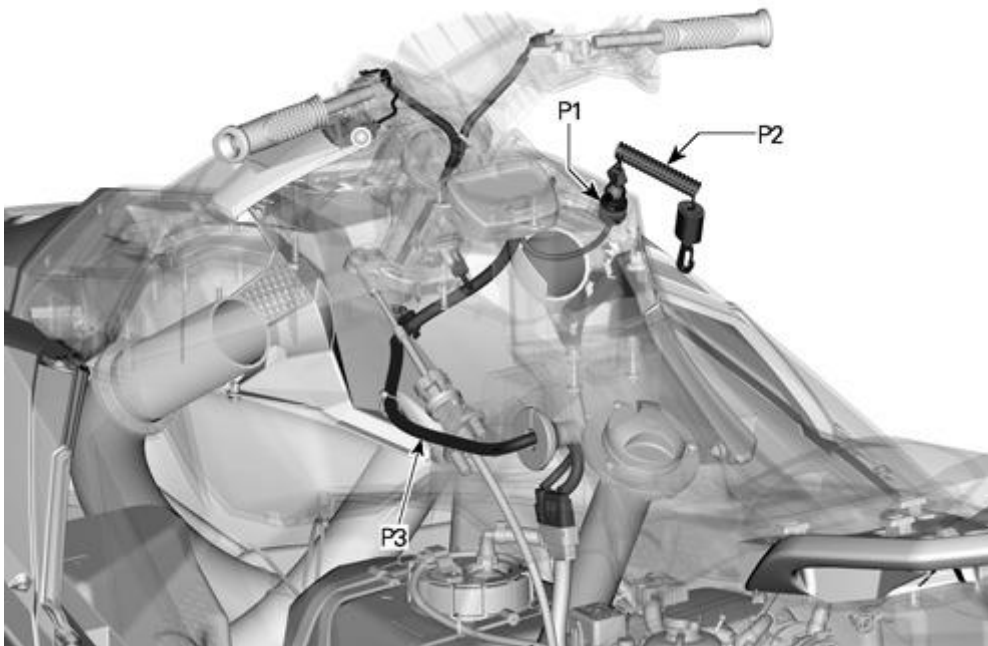

Artikel	Beschreibung	Artikelnummer	Menge
P1	DESS-Schalter	710007242	1
P2	Sicherheitsleine	278003400	1
	Kabelbaum – Spark ohne iBR	278003491 (nicht im Bausatz enthalten)	1
		2017 und früher: 278003490 (nicht im Kit enthalten)	
P3	Kabelbaum - Spark mit iBR	2018 und höher: 278003823 (nicht im Kit enthalten)	1
		Spark Trixx-Modelle benötigen außerdem VTS-Kabelbaum 278003195 (nicht im Kit enthalten)	

Verfahren

Vorbereitung

Disconnect and discard the section at the end of the harness to plug the engine cut-off switch.

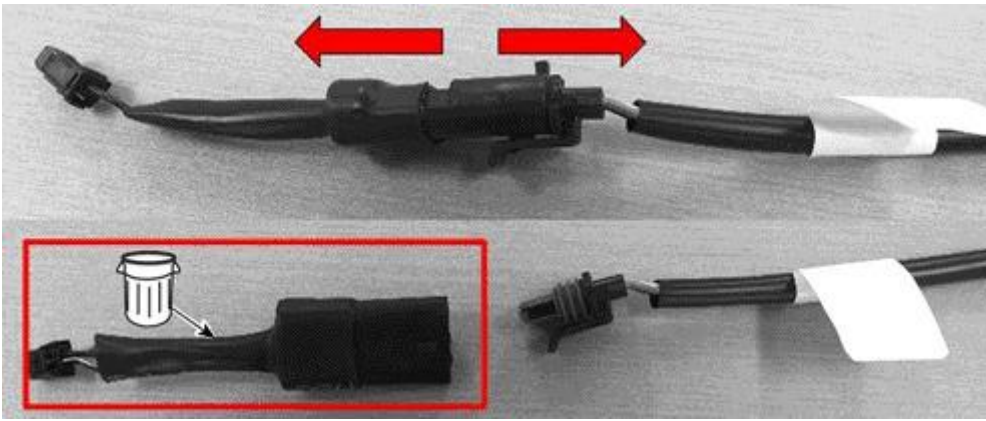

NOTE: For Spark Trixx models, harness 278003490 or 278003823 needs to be adapted with harness 278003195. Refer to WIRING HARNESS UPDATE PROCEDURE at the end of this instruction sheet.

Parts Removal

For Spark Models With TRIXX Package and Adjustable Riser

For parts removal, refer to appropriate subsections in your Shop Manual.

For All Other Spark Models Without TRIXX Package

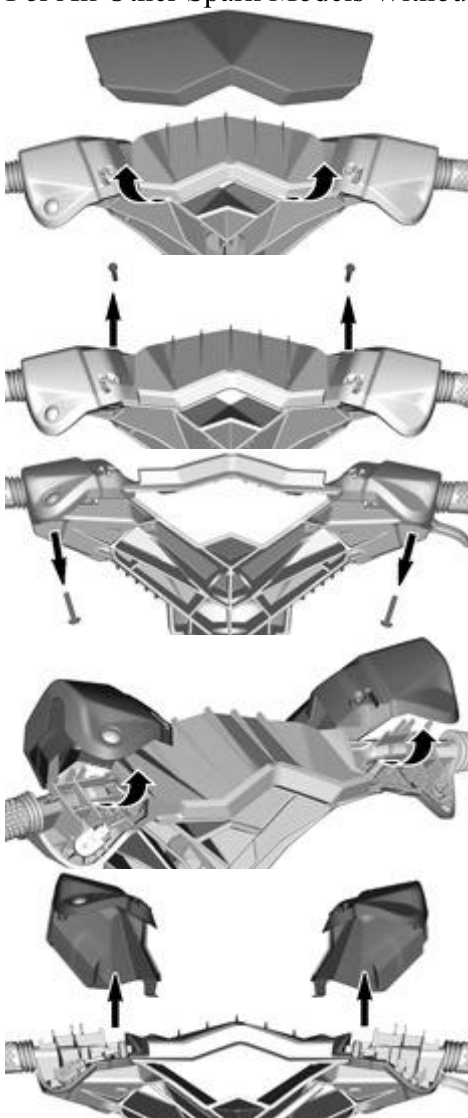

1. Disconnect START button and BRLS connectors. Push connectors into steering column.

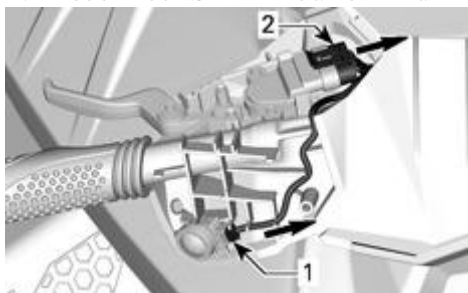

1. Start button connector
2. BRLS connector (if applicable)
2. Disconnect TAS connector and push connector into steering column.

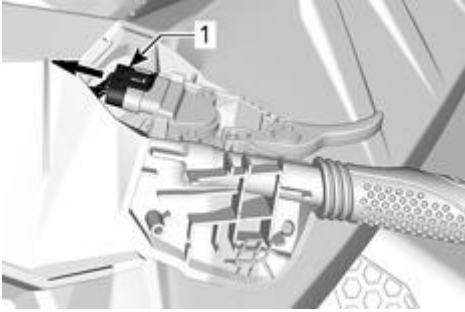

1. Throttle accelerator sensor (TAS)

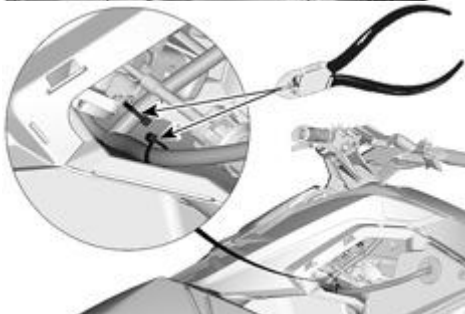
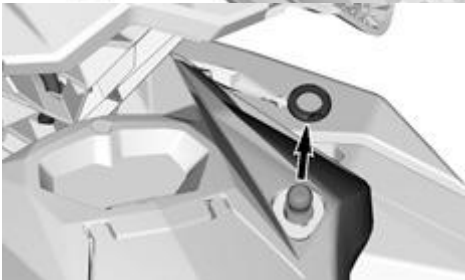

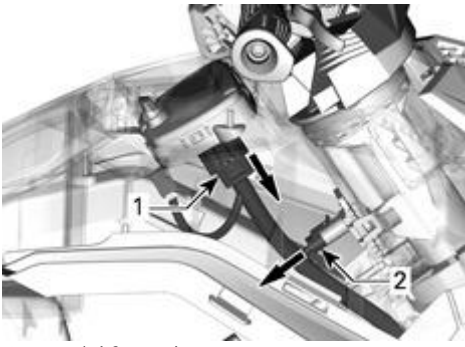

1. Multifunction gauge connector
2. O.T.A.S. switch connector.

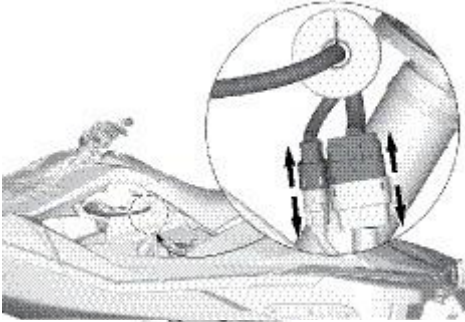

3. Remove steering harness and engine cut-off switch from vehicle.

#### Parts Installation

Install new steering harness and engine cut-off switch in the reverse order of the removal procedure. However, pay attention to the following.

#### Tightening torque

Engine cut-off switch nut

$1.75 \pm .25 \text{ N}\cdot\text{m}$  ( $15 \pm 2 \text{ lbf}\cdot\text{in}$ )

Secure wiring harness using new locking ties.

Activating Anti-Theft Function in B.U.D.S.

1. Connect the watercraft to latest applicable B.U.D.S. Refer to COMMUNICATION TOOLS AND B.U.D.S. subsection in the applicable shop manual.

**IMPORTANT:** Ensure all connections have been made before starting B.U.D.S. to allow proper operation.

2. Briefly press START/STOP button to power the ECM.
3. Install a tether cord on the engine cut-off switch to program a D.E.S.S. key.

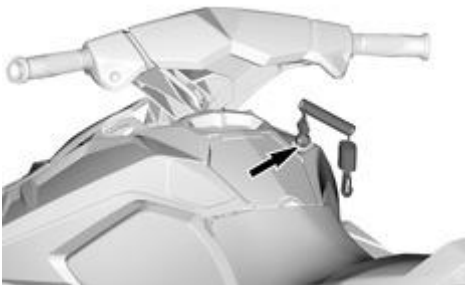

4. Read ECM using Read Data button.

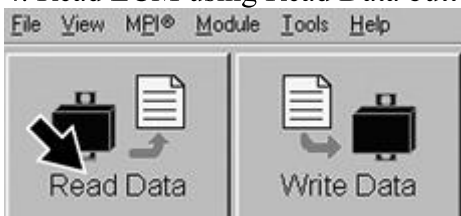

5. In the Anti-Theft System field of the Keys page, click on the drop down menu arrow and choose D.E.S.S..



6. Continue with ADDING A KEY in the PROGRAMMING A D.E.S.S. KEY procedure.

### Programming a D.E.S.S. Key

#### Adding a Key

1. Click on Keys tab.



2. Click on the Add Normal Key button at the bottom of the screen.

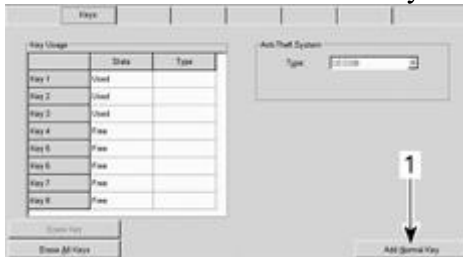

1. Add Normal Key button

3. After approximately 10 seconds, the following window will pop up confirming the new key has been saved in the PC computer.

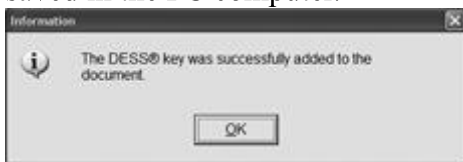

4. If programming is complete, write the changes to the ECM. Refer to WRITING CHANGES TO ECM .  
NOTE: To add another key, install other key to program on engine cut-off switch and repeat steps.

#### Erasing a Key

1. Install the tether cord on the engine cut-off switch.

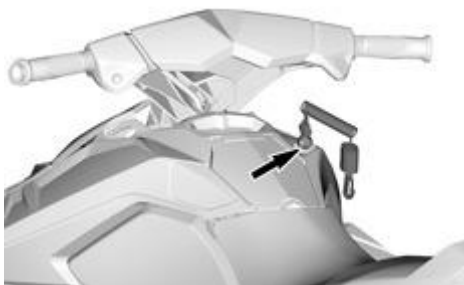

2. Click on Erase Key button at bottom of B.U.D.S. screen.



1. Erase Key button

After approximately 10 seconds the following message will appear.

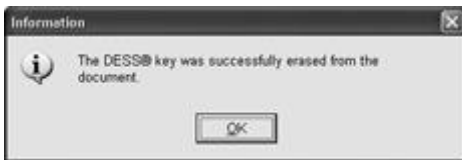

The key is now erased in the PC computer.

3. If programming is complete, write the changes to the ECM. Refer to WRITING CHANGES TO ECM .  
NOTE: To erase another key, install other key to erase on engine cut-off switch and repeat steps.

#### Erasing All Keys

1. Click on Erase All Keys button at bottom of screen.



1. Erase All Keys button

The following message will be displayed in B.U.D.S.



2. Click Yes to proceed with erasing all keys.

3. When done, program at least one new key to the vehicle. Refer to ADDING A KEY.

4. When programming is complete, write the changes to the ECM. Refer to WRITING CHANGES TO ECM .

NOTE: If there isn't at least one key programmed to the ECM, B.U.D.S. will not allow changes to be written to the ECM and will prompt you to add a key.

#### Writing Changes to the ECM

Save the changes made in B.U.D.S. into the ECM as follows.

1. Click the Write Data button.

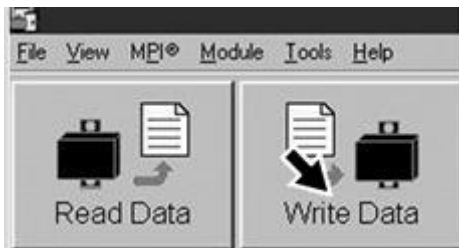

NOTE: If for some reason the writing operation fails, exit B.U.D.S. Restart B.U.D.S. and reenter all the previously lost information.

2. After the write operation, remove the key from the engine cut-off switch.

3. Try the key(s) on the PWC.

4. Install all remaining parts in the reverse order of the removal.

#### Wiring harness update procedure

Only for Spark Trixx Models or Models with Adjustable Riser Handlebar

1. Remove rubber sheath from VTS harness (P/N 278003195).

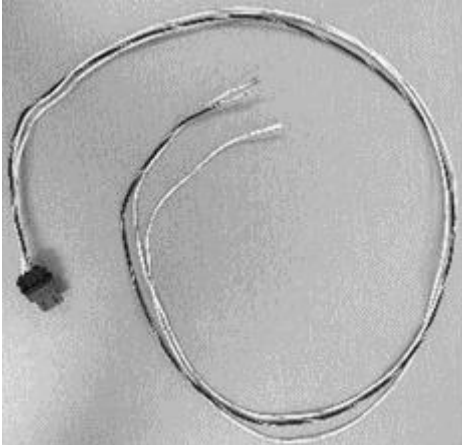

vtS Harness without rubber sheath

2. Cut piece of 150 mm (5-29/32 in) long of the rubber sheath previously removed.
3. Insert piece of rubber sheath on VTS harness.

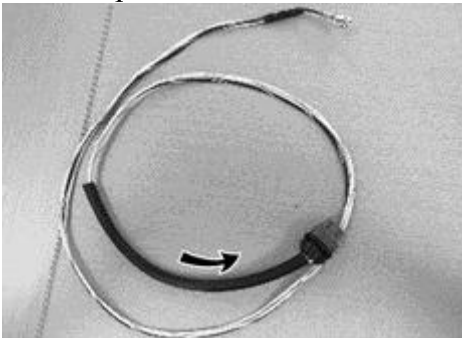

vtS Harness with piece of rubber sheath

4. Remove tape from handlebar harness junction.

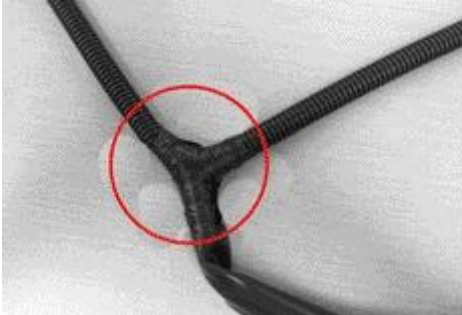

handlebar harness junction

5. Insert VTS harness in starter switch harness protection tube.

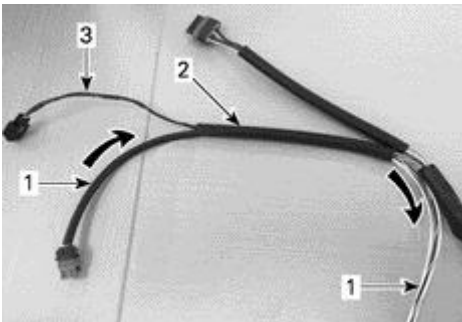

1. VTS harness

2. Starter switch harness protection tube
3. Starter switch harness
6. Insert VTS harness in the rubber protection. Route it to the junction as shown in image below.

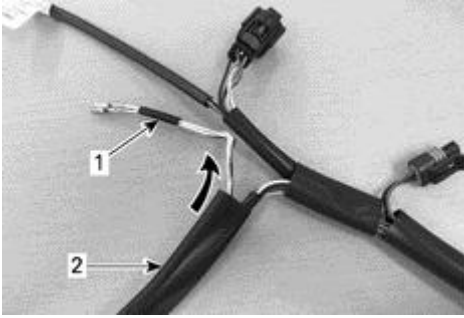

1. VTS harness
2. Rubber protection
7. Tape handlebar harness junction.

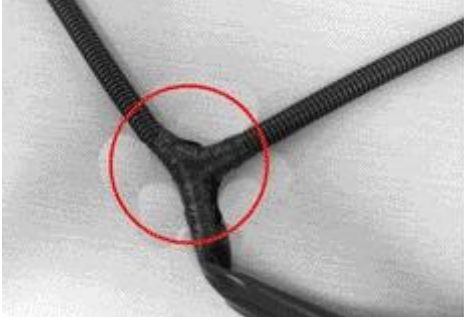

handlebar harness junction

8. Connect VTS switch to harness.



9. Route harness (see Spark Trixx MY17 shop manual procedures).

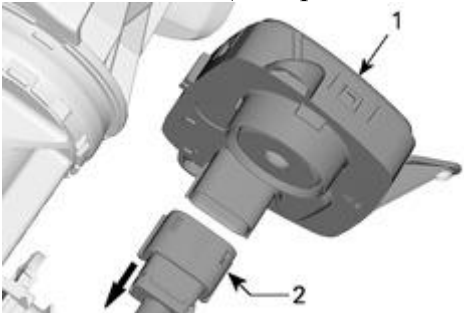

1. Multifunction gauge
2. Gauge connector

10. Insert a small flat screwdriver in the pry holes of the socket locator, on the socket side of the connector.

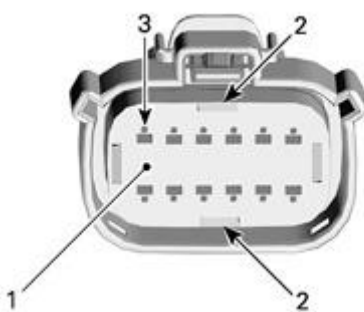

1. Socket locator
2. Pry holes

3. Holes for inserting terminal extractor tool

11. Carefully pull the socket locator out to the detent position (approximately 5 mm).

NOTE: Do not remove the socket locator from the connector housing.

12. Insert the extractor tool in the small hole adjacent to the socket.

NOTE: Push the extractor tool in only as far as required to release the lock from the socket. The tool should slide along the socket and be inserted between the socket and the lock.

### Required tool

FCI TERMINAL EXTRACTOR TOOL (P/N 54241678)

or

MOLEX 150 TERMINAL EXTRACTOR TOOL (P/N 63813 - 1500)



FCI Terminal extractor tool (P/N 54241678)



MOLEX 150 Terminal Extractor Tool (P/N 63813 - 1500)

13. Gently remove the plastic blanks indicated in the following illustration using the long nose pliers.

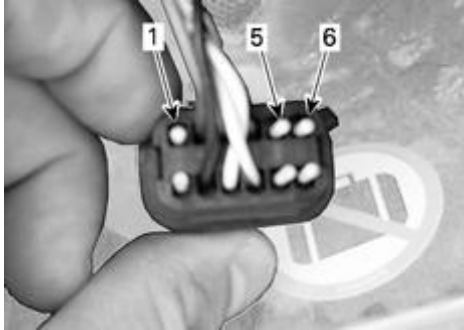

Plastic blank pins to remove

Position 1

Position 5

Position 6

14. Insert pins from the new VTS wire harness [P3] through the back of the multifunction gauge connector as per following illustrations.

NOTE: When inserting the pin, insert the stepped portion facing the notch in the connector pin hole. No tool required.

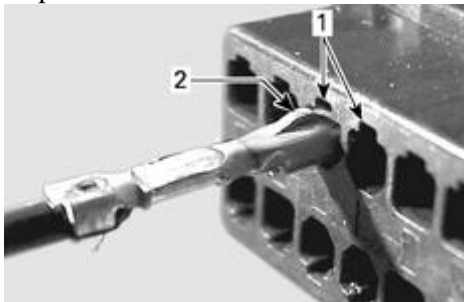

Typical - pin insertion

1. Notch

2. Stepped portion towards notch

### Insertion of VTS Switch Wires in MULTifunction Gauge Connector

Position 1

BLACK/WHITE wire

Position 5

WHITE/BLUE wire

Position 6

WEISS/GRÜNER Draht

15. Drücken Sie den Stift hinein, bis die Stiftverriegelung den Stift einrastet.

16. Ziehen Sie vorsichtig am Stift, um sicherzustellen, dass er richtig verriegelt ist.

17. Wiederholen Sie die vorherigen Schritte für jeden einzusetzenden Stift.

18. Schieben Sie den Stiftsucher in die verriegelte Position in den Anschluss.

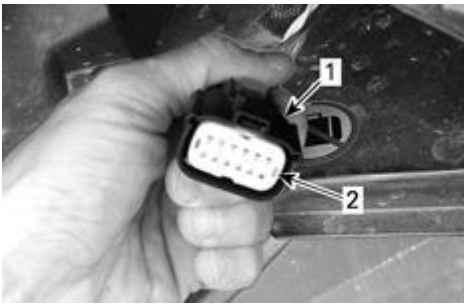

1. Anschluss für Multifunktionsanzeige
2. Fixierstift in Verriegelungsposition bringen